

COMPROD COMMUNICATIONS LTD.

Customer Instruction Manual

Model #BDA-138174

VHF BIDIRECTIONAL AMPLIFIER Technical manual

© 2018, Comprod Communications LTD.

88 Industriel Blvd
Boucherville, QC, J4B 2X2
Phone 1.800.641.1454 • Fax 1.800.641.4616

3405 N. Benzing Road
Orchard Park, NY, USA 14127
Phone 1.800.603.1454 • Fax 1.800.554.1033

IMPORTANT:

The integrator is responsible for its product to comply with IC ICES-003 & FCC Part 15, Subpart B – Unintentional Radiators. Final product must comply with unintentional radiators before declaring compliance of their final product to Part 15 of the FCC Rules and Industry Canada ICES-003.

VHF BIDIRECTIONAL AMPLIFIER TECHNICAL MANUAL

Based on the philosophy of Anytime, Anywhere, and Anyplace, the VHF amplifier module is designed for ease of use to be adaptable to various needs in the field. Recently developed technologies are utilized. With the use of modern integrated circuits and RF components, this Comprod design ensures constant performance and a reliable amplifier system.

The VHF MHz amplifier has also been designed with government agencies in mind. These agencies require the highest level of performance and quality for continuous duty solutions while providing maximum coverage. This amplifier module is aimed for use in buildings, tunnels, government facilities, airports, providing the required communication throughout.

The amplifier module helps to increase the coverage of RF communications in buildings or places where RF is unable to penetrate from the base station site. The Amplifier Module can be used in both Uplink and Downlink directions and it is connected to either a radiant cable, or a distributed antenna system at one end. At the other end it's connected to the donor antenna.

Main Specifications:

No	Parameter	Specification	Remarks
1	Operating Frequency	138 ~ 174MHz	The unit tested and certified for: -FCC allocation values: 150.05-173.4 MHz -IC (Industry Canada) allocations Values: 138-144 MHz 148-149.9 MHz 150.05-174 MHz
2	Pass Bandwidth	-	Tuned to custom Freq
3	Passband Ripple	± 1.5 dB	
4	Maximum Gain	+80dB	
5	Nominal Gain	+75dB	RFM only
6	Input Manual Attenuation	30dB / 2dB step	controlled by Rotary switch
7	Output Manual Attenuation	15dB / 1dB step	controlled by Rotary switch
8	Automatic Level Control	30dB	controlled by MCU
9	Output Power	30 dBm	
10	Noise figure	2dB	Max Gain, RFM only
11	IP3	+48dBm	
12	1dB compression	39 dBm (min)	
13	VSWR	1.5 max	
14	Alarm	AGC, S/D, VSWR, OSC	Alarm: High, Normal Low

15	Voltage	+48V +6V	
16	Power consumption	35 W (max) when connected to 48 V. DC 40 W (max) when connected to 120 V. AC	700 mA max ; 48 V. DC 3100 mA max; 120 V. AC
17	Impedance	50Ω	
18	In/Out Connector	N (F)	
19	Size(W*H*D)	Depends on the filtering system	
20	Operating Temp	-20 ~ +55°C	

Block Diagram Details

- The VHF Amplifier module contains a (Low Noise Amplifier) LNA designed to detect a very weak signal. This stage is bypassed if the signal level at the input is higher than -20dBm
- The LNA is followed by an Automatic Gain Control (AGC). The AGC circuit measures composite power level at the VGA input and adjusts the gain automatically, in order to maintain a constant signal level at the VGA output delivered to the Power Amplifier (PA). Channel filters are inserted, in order to reject adjacent channel signals and to improve the signal quality.
- The PA provides good performance for both linearity and efficiency. This amplifier has a heat sink mounted to it. It has a high compression point and a high 3rd order Intercept point.
- The unit can operate with AC or DC power supplies. The main AC input accepts 50/60 Hz with a 115 to 220 V AC power source. The Power Supply Unit (PSU) converts AC to DC voltages to supply DC power to the amplifiers, monitoring and control units. The unit can be fed directly with DC power, by selecting the DC option on the AC/DC switch and connecting +48 V to the DC input connector. The operator must ensure that this external DC power supply is compliant with FCC limits on radiated and conducted emissions.
- The unit does not have a built-in UPS/Battery system. In case of inconsistency in the AC line power, surge protection, short blackouts, high crossover time from the line AC to generator power, circuit breaker for short circuit and overload protection, etc., an external UPS/Battery system is recommended.
- The amplifier is intended to be used in a BDA system that includes two duplexers; one at the BTS port allowing the use for only one donor antenna for both UL and DL. The second duplexer is mounted at the Service DAS antenna port. These duplexers provide at least 100 dB isolation at each end between the two paths.
- A set of manual gain controls (MGC), ranging from 0 to 30 dB in 2 dB steps. Another set ranging from 0 to 15 dB in 1 dB steps are also added in the chain for additional attenuation if it is needed.

UDA LINK BLOCK DIAGRAM

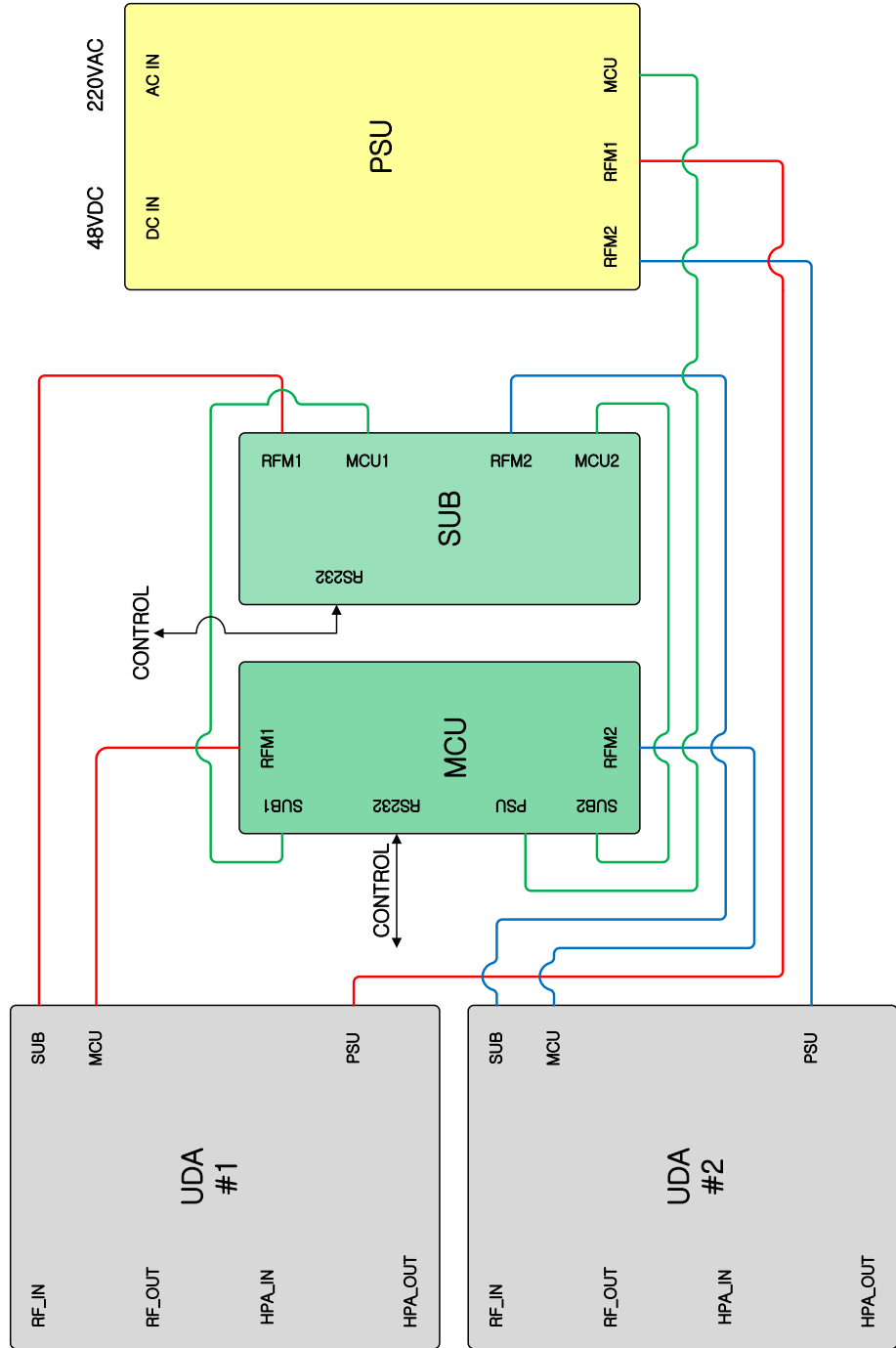

VHF BIDIRECTIONAL AMPLIFIER TECHNICAL MANUAL

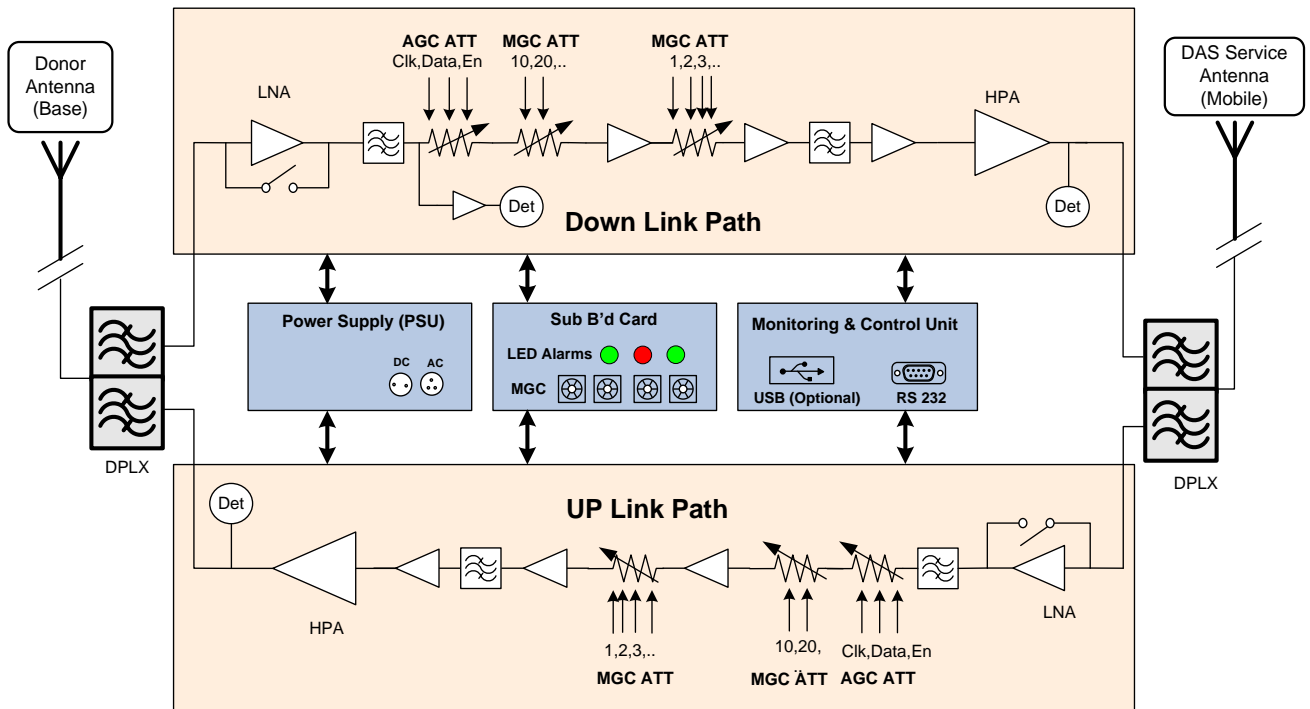

Led Indicator Alarm and Manual Level Control.

- The unit has visual alarms using LED indicators for the following conditions; AGC, S/D, OSC, power and VSWR.
 - o AGC: alarm turns red when the AGC is not delivering any attenuation. This can happen in two situations. Either the AGC is turned off by the user (see monitoring and control section) or if the signal at input of the DL is too weak. This is not necessarily a failure. It can just be a warning that the signal from the BTS is too weak.
 - o S/D: The shutdown indicator turns red when the system is in automatic shutdown. This happens when the internal temperature is too high or when the output power exceeds the maximum limit allowed. When the RF module is turned off by the user (see monitoring and control section) the S/D indicator will start flashing.
 - o The Power indicator turns red when the RFM is not receiving the correct DC power.
 - o OSC indicator turns red when oscillation occurs in the system.
 - o VSWR indicator turns red when an antenna mismatch occurs in the system.



Monitoring and Control

The monitoring and control function is possible by connecting the BDA through a serial RS232 connector. A Serial to USB adapter is available upon request.

The software designed for this purpose is provided. This software should be installed on a computer with Windows, XP, Vista, 7, 8 or 10 versions. When you run the software, you will see the screen shown below.

Set the proper com port (1~99) or AUTO and press Connect (recommended).

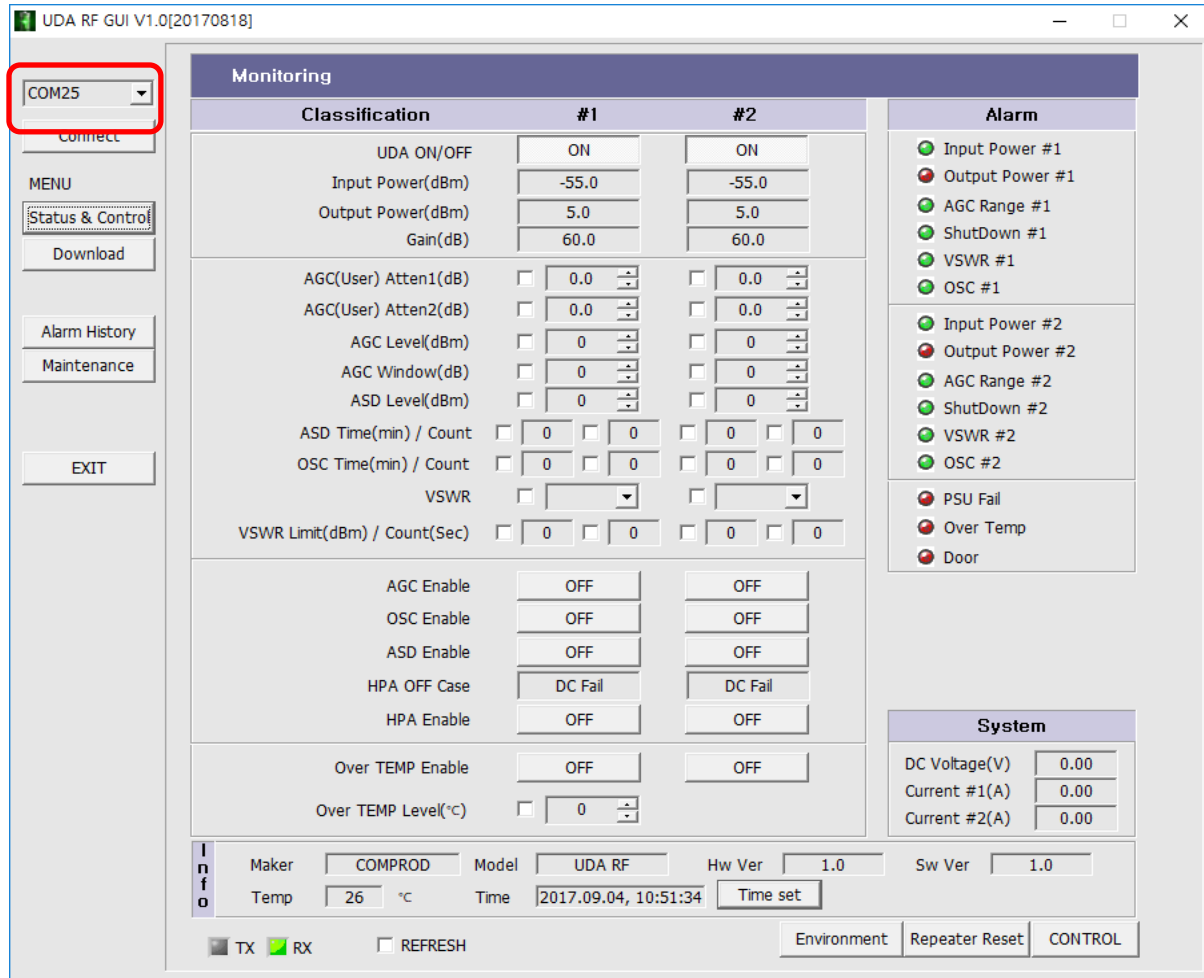

VHF BIDIRECTIONAL AMPLIFIER TECHNICAL MANUAL

When GUI connect to PC properly, TX, RX LED should be blinking and all parameters is displayed.

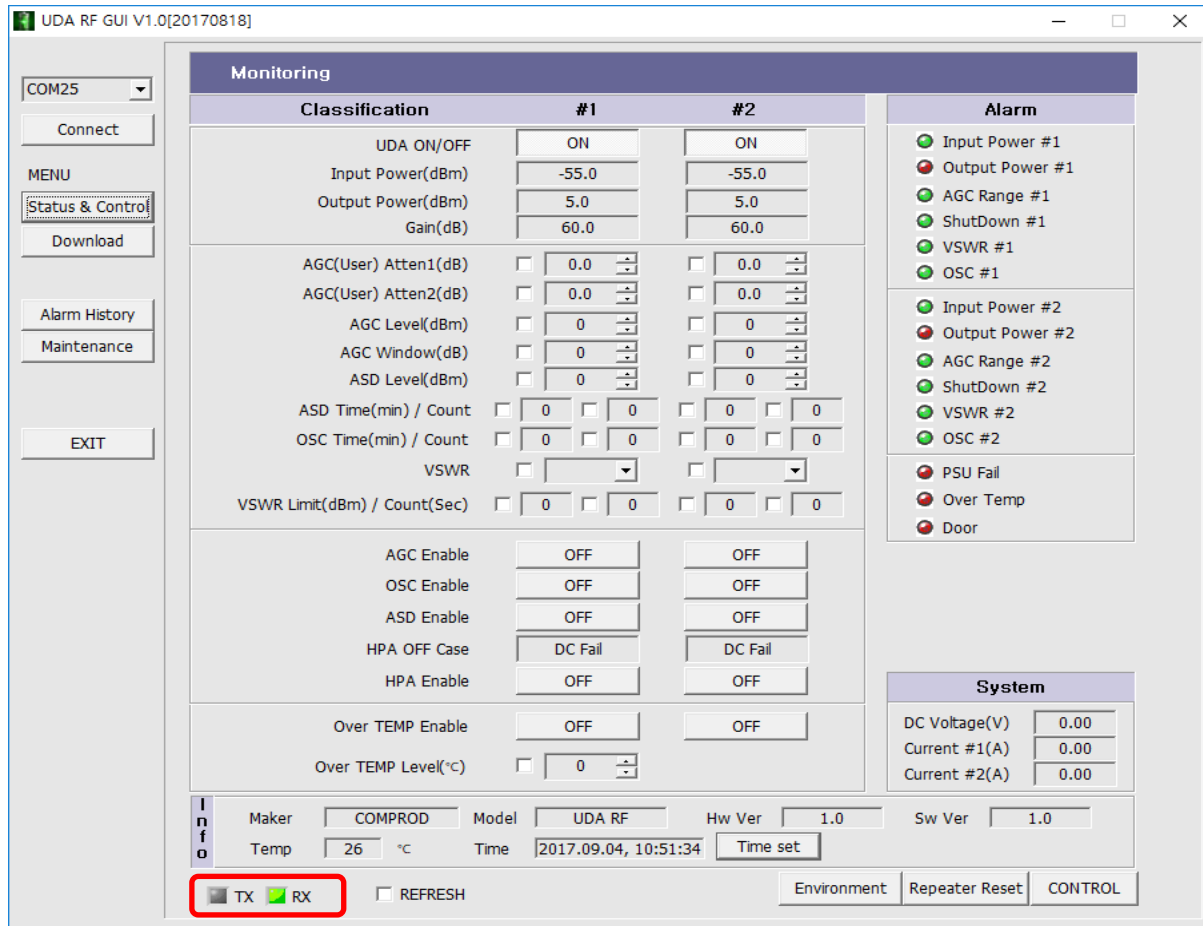

- Status & Control

Status & Control menu consists of RF Control, PSU status, System Info, and Alarm status.

UDA ON/OFF: The MCU of UDA can control two UDA's. If #1 is on and #2 is off, the parameters of #1 are displayed and the parameters of #2 are hidden.

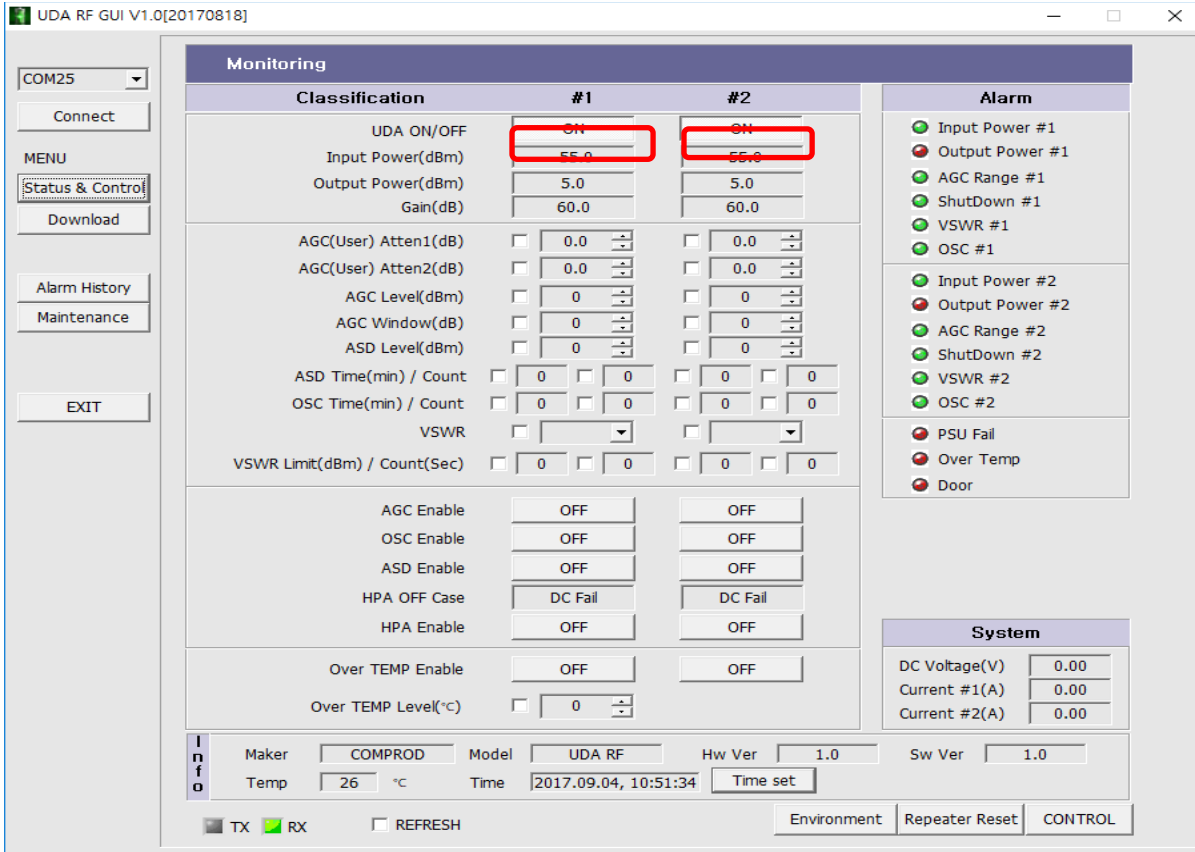

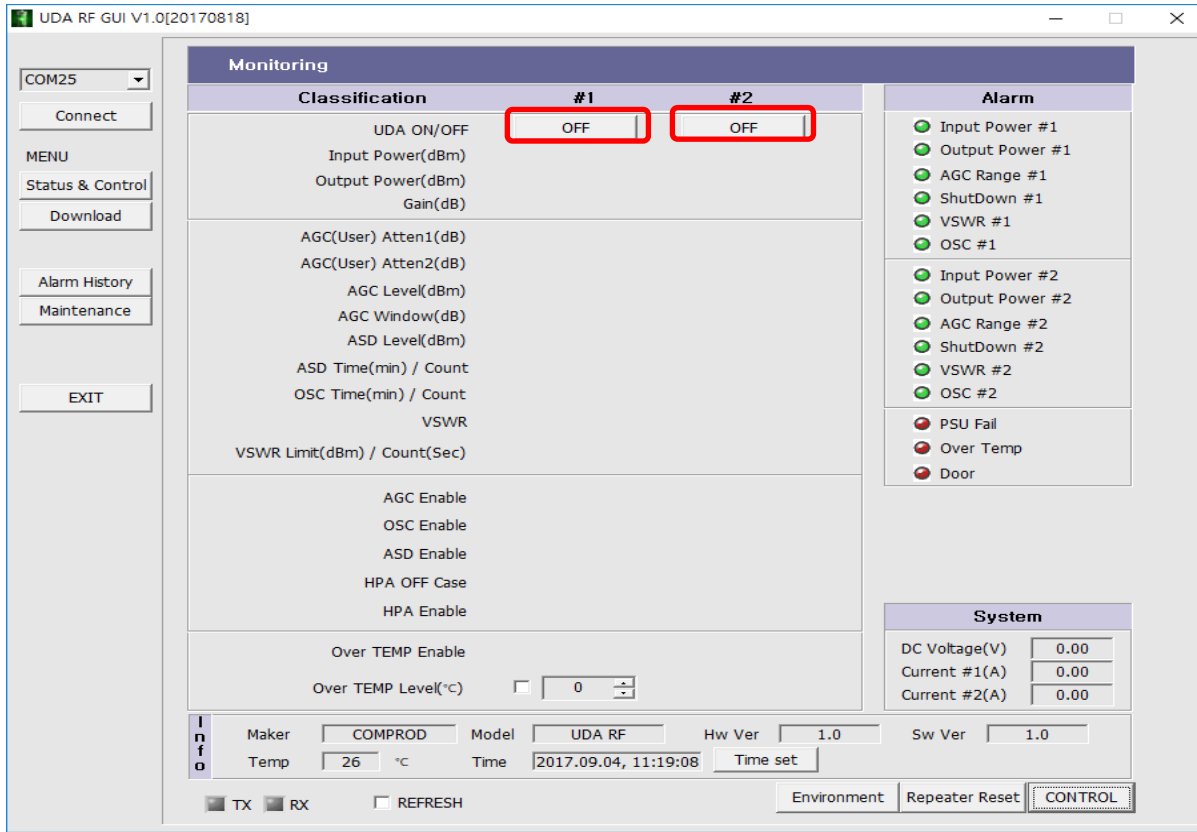

HPA Enable: When HPA Enable is turned off, the entire amplification chain turned off. In this case the Shutdown alarm will flash indicating that the system has been shut down by the user.

AGC Enable: When AGC is enabled or ON, the attenuation in the AGC Atten window is determined automatically by the system. If the AGC is off, the user can decide on the attenuation by changing the value.

OSC Enable: When OSC Enable is ON, the system is checking for oscillation caused by lack of isolation. If the system detects oscillation The HPA is turned off automatically.

ASD Enable: When ASD is enabled, the system will shut down as soon as the output level reaches the value of ASD Level.

Over TEMP Enable: When Over TEMP Enable is ON, the system will shut down as soon as the internal temperature of the system exceeds Over TEMP Level.

VSWR Alarm: When output VSWR is over limit, a VSWR Alarm will occurred.

VSWR: The threshold of VSWR Alarm can be set to 3:1, 6:1 or 9:1.

VSWR Limit(dBm) / Count(Sec): When the output power is low, VSWR measuring is not accurate. Limit(dBm) sets the output power limitation of VSWR measuring. When you set the limit to 28dBm, VSWR Alarm will not occur below 28dBm output power even if the output port is opened. Count(Sec) is measuring the time.

- **Alarm Definitions:**

Input Power #1/#2: The signal from the antenna is too strong, or there is feedback from the internal to the external antenna.

The system will continue to operate but the LNA will be bypassed."

Output Power #1/#2: The output power is exceeding 33 dBm. Turn on AGC or adjust the manual attenuators.

AGC Range #1/#2: The signal is exceeding the AGC range. Adjust the manual attenuators.

Shutdown #1/#2: The HPA is shut down see HPA OFF Case for the reason why.

VSWR #1/#2: Please check output port connections, cables and antennas to keep a good VSWR.

OSC #1/#2: Please check Isolation between the Donor and the Service antennas. Isolation should be greater than System gain + 15dB.

PSU Fail: Power Supply Unit Failure.

Over Temp: Inside temperature exceeds the Over TEMP Level setting.

Door: The access door of the UDA is not properly closed.

- **Environment.**

Click on: Environment, opens up a smaller window, dragged to the right, reveals the UDA #1 and UDA#2 Power levels (Input and output).

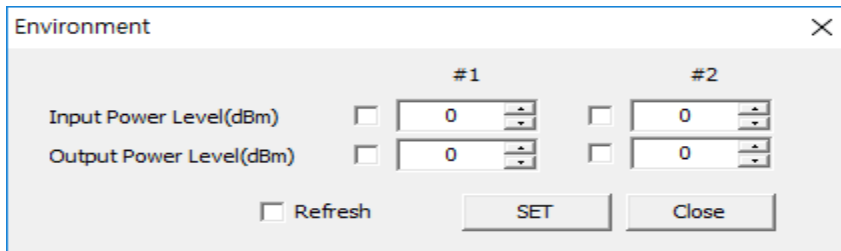

- **Firmware Download**

This is used to upgrade the firmware in the UDA.

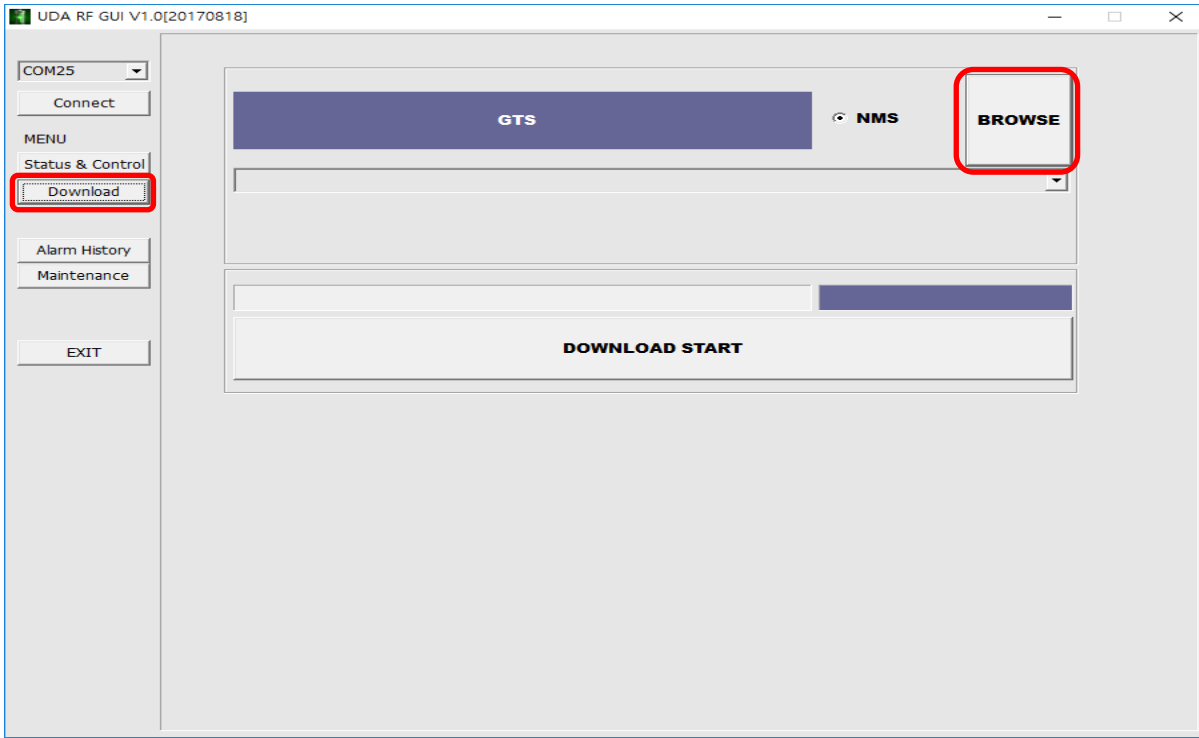

Click on BROWSE, select the file and click on Open.

Click on DOWNLOAD START, download will proceed.

VHF BIDIRECTIONAL AMPLIFIER TECHNICAL MANUAL



When download is finished properly “New Download Success!!!” message will pop up.

- **Alarm History**

This is used to access the list of events that the UDA has recorded.

By clicking DATA REQ a list of events is relayed onto the screen.

Clicking on CLEAR, erases the entries.

By clicking FILE SAVE all data can be saved to a file.

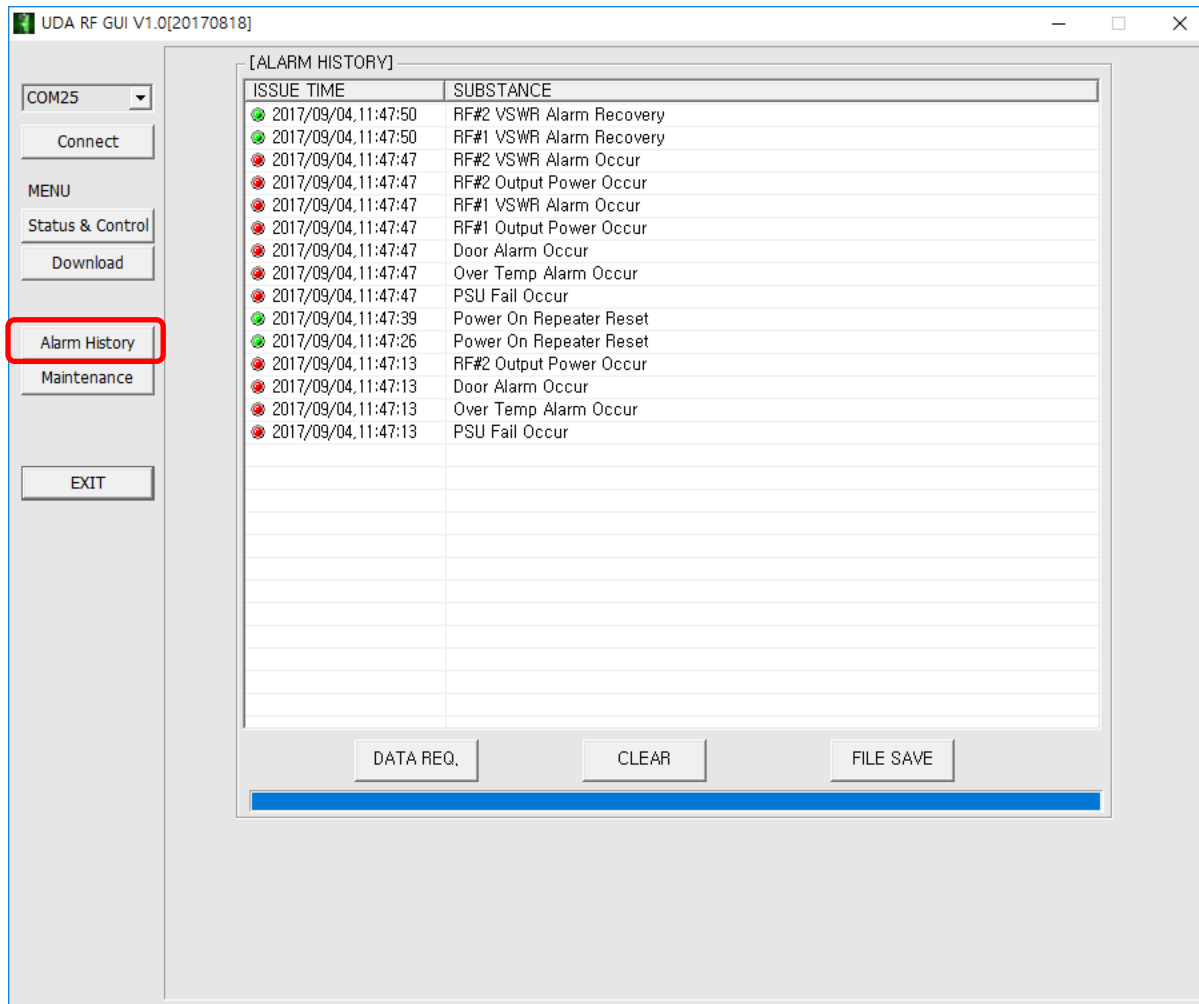

- Maintenance

By clicking READ a working list is relayed onto the screen.

Clicking on WRITE, you can generate a working list that is shown in the window.

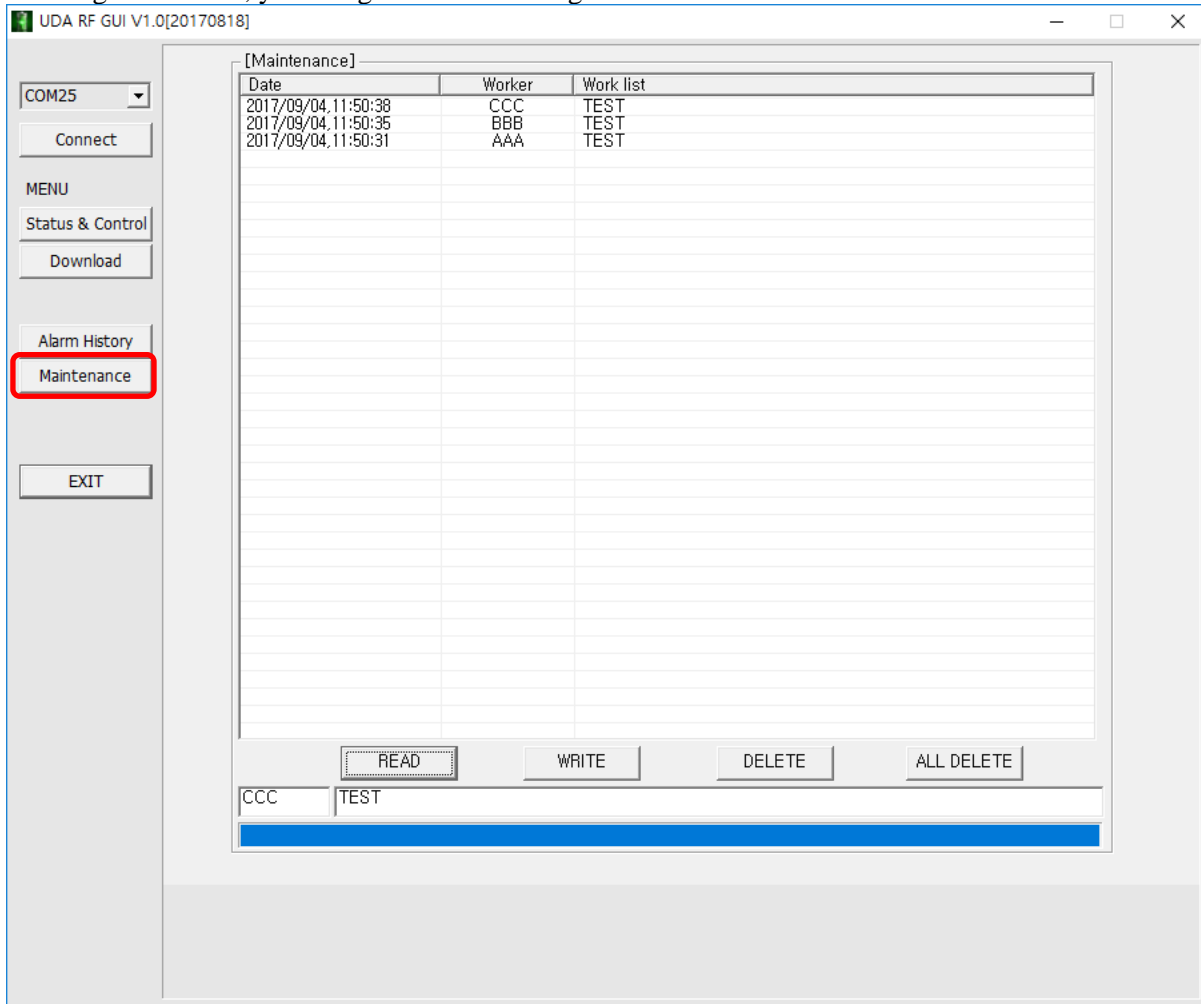

Dry Contact Alarms

Each BDA has two 16 PIN Female connectors for Dry Contact Alarms. Male connectors, with labeled wires, are also supplied with the unit for easy connection.

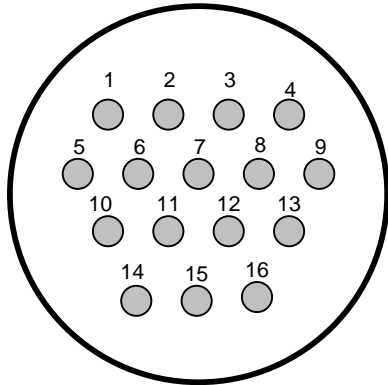

UL

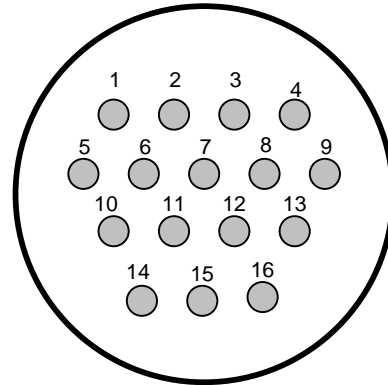

DL

UL Dry Contact Alarm connection		DL Dry Contact Alarm connection	
PIN	Description	PIN	Description
1	NC DC Relay	1	NC DC Relay
2	COM DC Relay	2	COM DC Relay
3	NO DC Relay	3	NO DC Relay
4	NC Oscillation	4	NC Oscillation
5	COM Oscillation	5	COM Oscillation
6	NO Oscillation	6	NO Oscillation
7	NC RF System Failure Relay	7	NC RF System Failure Relay
8	COM RF System Failure Relay	8	COM RF System Failure Relay
9	NO RF System Failure Relay	9	NO RF System Failure Relay
10	NC AC Relay	10	NC AC Relay
11	COM AC Relay	11	COM AC Relay
12	NO AC Relay	12	NO AC Relay
13		13	
14	NC VSWR Donor Antenna	14	NC VSWR Donor Antenna
15	COM VSWR Donor Antenna	15	COM VSWR Donor Antenna
16	NO VSWR Donor Antenna	16	NO VSWR Donor Antenna

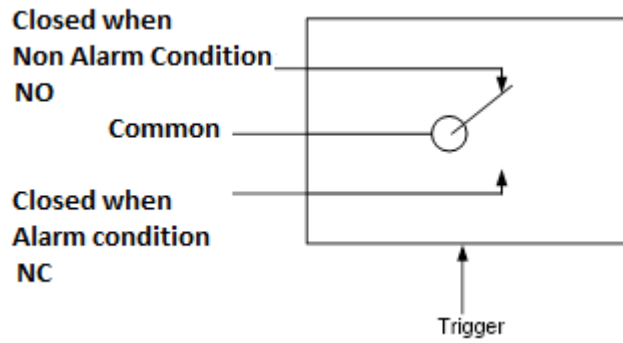

Relay Shown in Non-alarm Condition

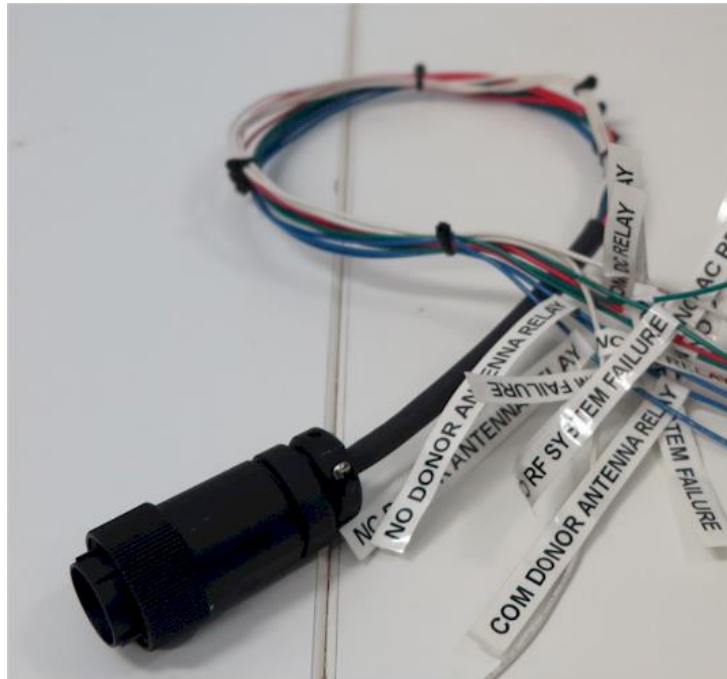

Connector kit with labeled wires supplied with the unit.

Unpacking

- 1) If the shipping box is damaged, do not open it, take a picture and contact the freight carrier for a claim.
- 2) If the shipping box is not damaged, the VHF BDA should be unpacked soon after delivery and carefully inspected for possible shipping damage. It is the customer's responsibility to file claims with the freight carrier if damage is suspected and that is usually limited to a certain time period after delivery.
- 3) Carefully compare the packing slip(s) against the package contents to verify the receipt of all expected items.
- 4) Retain all product documentation and make sure that manuals are forwarded to the appropriate site management, installation and service personnel.

Lightning Protection

Although relatively rugged, lightning can damage the internal working mechanisms inside the BDA. We recommend the installation of a lightning surge suppressor in the transmission line where it enters the building prior to the BDA. The suppressor should be grounded to the building ground bus at the transmission line entry point. Choose a suppressor that will handle the expected amount of input power from the BDA to the donor antenna.

Antenna Installation

Buildings that are not designed or upgraded for antenna systems need special attention for antenna mounting, equipment installation and cable runs. There are many variables involved in the design of a DAS system (distributed antenna system).

There are structural requirements for the location of the outdoor antenna (Donor); masts, towers, building structure for handling wind and ice loading.

- Protection of antennas and cables from building occupants and general human interaction.
 - Installers/designers must be aware of general seating, foot traffic areas and different access points.
 - All Antennas must be designed for the working frequency, and ensure they meet the exposure requirements.
- The donor antenna and distribution antennas must have 12 dB + the Maximum gain of the amplifier of isolation between them. Less isolation will cause the module to overload and oscillation will occur which may result in damage to the amplification module.
- Antennas should be mounted following the manufacture's guidelines for RF connection and be affixed to the building at the location of the desired signal.
- All cables used in the DAS system shall be 50 Ohms and clamped properly to ensure the cables 50 Ohm impedance characteristics. Improper clamps will change the impedance of the cable at that location thus changing the efficiency of the system.
- Antenna placement through the DAS system is important to produce a balanced, distributed signal. The use of correct decouplers, power dividers, and signal taps is important to promote a balanced system.

BDA Installation

DO NOT APPLY A.C. POWER TO THE BDA UNTIL CABLES ARE CONNECTED TO BOTH PORTS OF THE BDA AND THE ANTENNAS.

1. Mount the BDA on the wall with the RF connectors pointing DOWN. Using appropriate screws and anchors, attach the BDA to the wall using the four mounting holes on the side flanges.
2. Ensure that the isolation between the donor antenna and the service antenna is at least 12 dB greater than the BDA gain. (Use the higher of the Uplink and Downlink gains reported on the BDA test data sheet).
3. Connect the cable from the donor antenna to the BDA connector labeled “BASE” and the cable from the service antennas to the BDA connector labeled “MOBILE”.
4. Open the door of the enclosure of the BDA and verify that both of the PSU switches are in their factory preset “ON” positions. Close the panels.
5. Connect the AC power cord to the BDA and then to the power source. Verify that the “Power ON” lamp is illuminated.
6. Connect the computer with the software installed via RS 232 serial connector or via a USB port with a USB to serial adapter.
7. On the RF_BDA_GUI make sure that AGC Enable, ASD Enable and HPA Enable functions are all turned ON.

Installation of the BDA is now complete. To adjust the gain controls to suit the specific signal environment, refer to the section on Monitoring and Control.



Label position on the BDA

The amplifier unit has its FCC/IC, warning and Signal Booster Class B labels on the front cover, as shown in the above picture. These labels must not be removed.

The label on the enclosure as indicated should have the following text:

Model: BDA138174
FCC ID: WDM-BDA138174
Model: BDA138174
IC: 7755A-BDA138174
HVIN: BDA138174 FVIN: BDA RF GUI V2.0





Additional labels on the BDA.

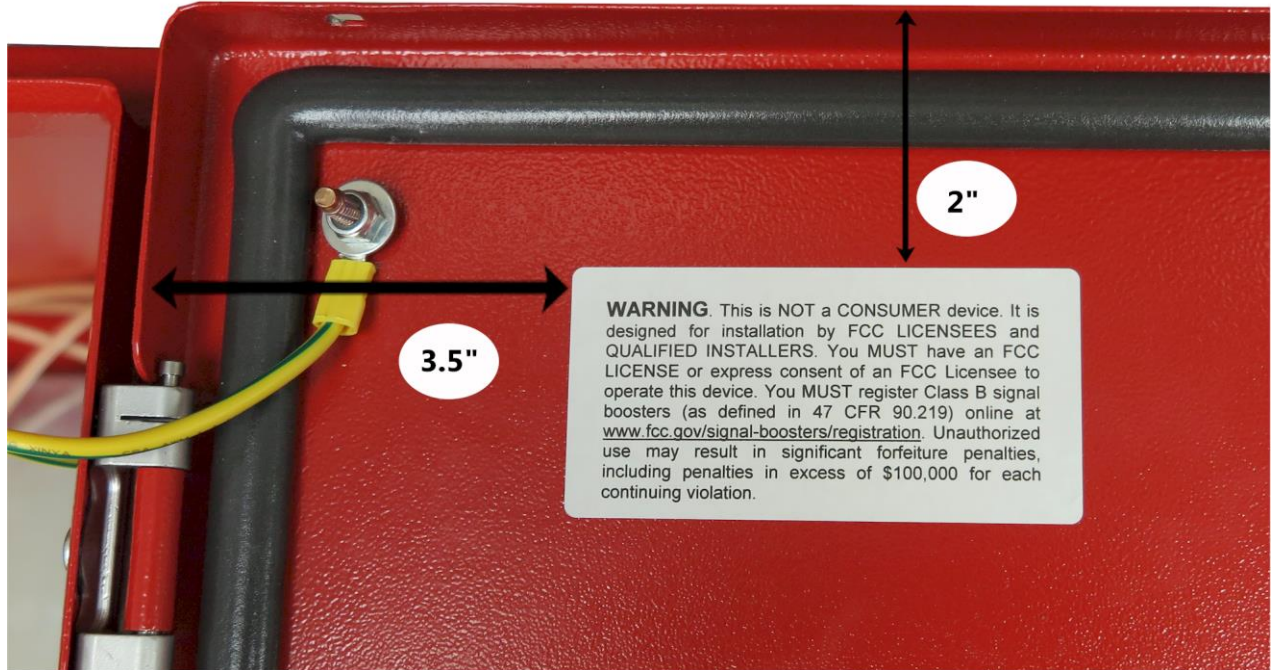

Warning if the unit is destined to US market



Warning if the unit is destined to Canadian market

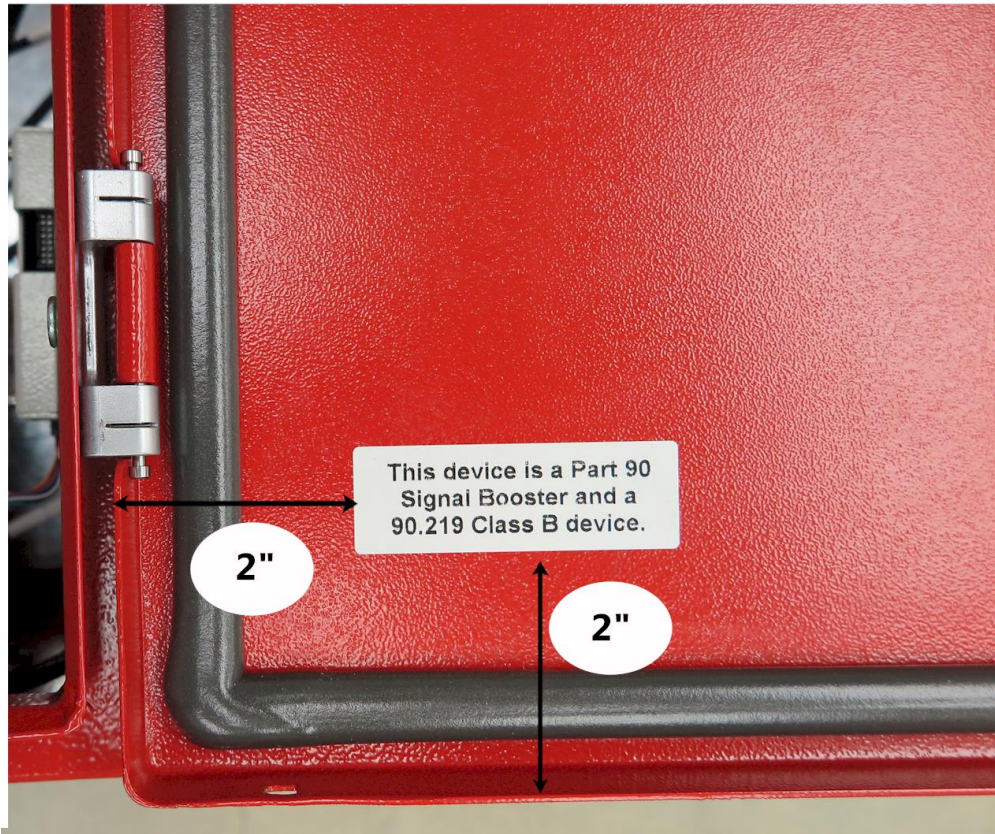

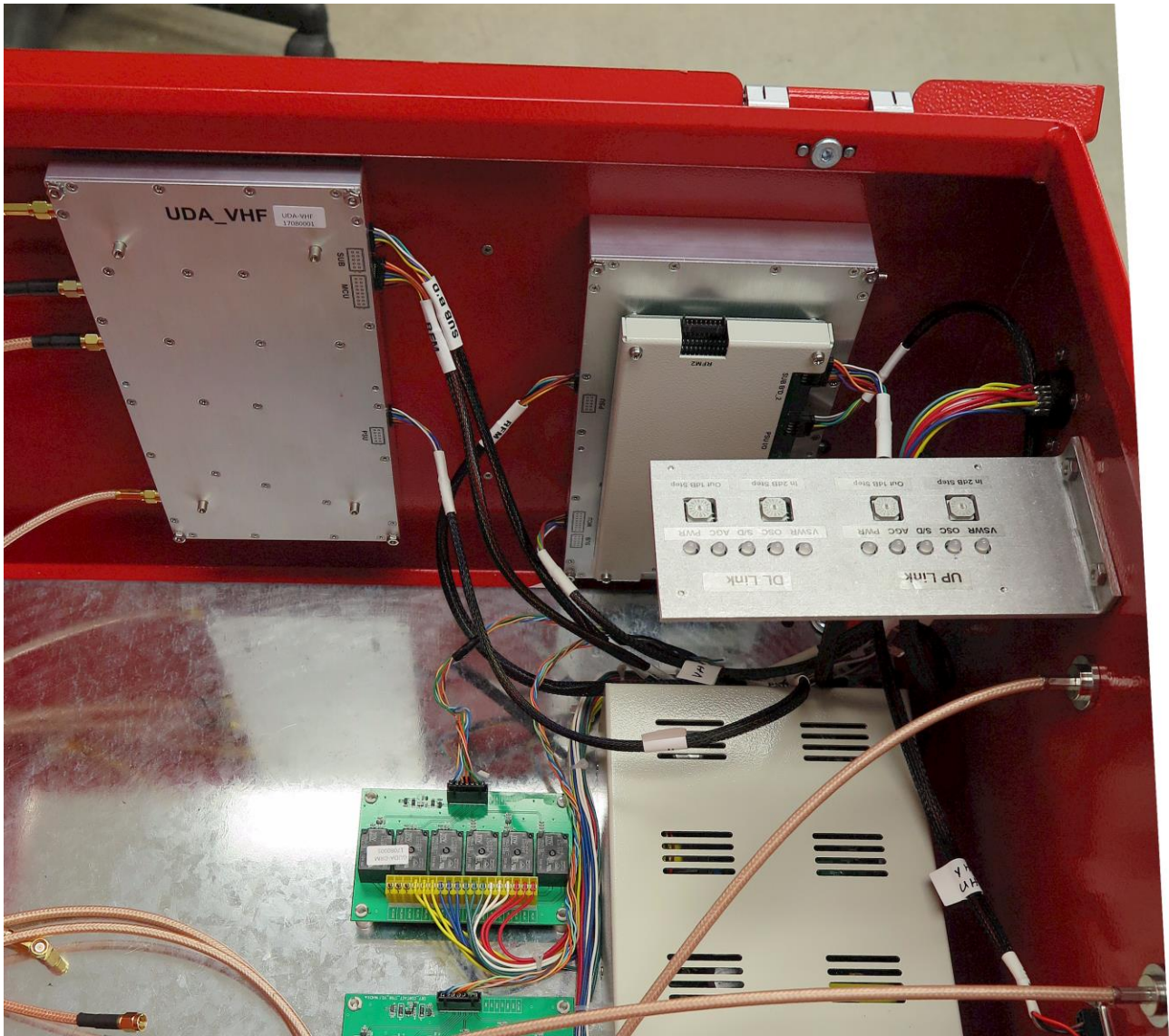

Additional label



VHF Bidirectional Amplifier

Warnings and Notices

 **WARNING:** *Changes or modifications not expressly approved by Comprod Communications could void the user's authority to operate the equipment.*

 **WARNING:** *Service antenna should have 2.15 dBi (0dBd) Gain Max.*

 **WARNING:** *To satisfy RF exposure requirement, the RF exposure safe separation distance is 38cm*

Notice:

This equipment has been tested and found to comply with the limits for a Class A digital device, pursuant to Part 15 of the FCC Rules. These limits are designed to provide reasonable protection against harmful interference when the equipment is operated in a commercial environment. This equipment generates, uses, and can radiate radio frequency energy and, if not installed and used in accordance with the instruction manual, may cause harmful interference to radio communications. Operation of this equipment in a residential area is likely to cause harmful interference in which case the user will be required to correct the interference at his own expense.

This device has been designed to operate with the antennas having impedance of 50 ohms. The use of high gain antennas exceeding the values specified by the manufacturer is strictly prohibited.

FCC link for Part 90 Class B Signal Booster Registration & Discovery:
<https://signalboosters.fcc.gov/signal-boosters/>

Definition of Terms:

AGC – Automatic Gain Control

ASD – Automatic Shut Down

Attenuate – Reduce sensitivity or gain

BDA – Bi-Directional Amplifier

BPF – Bandpass Filter

BTS – Base Transceiver Station

DAS – Distributed Antenna System

DL – Downlink – The signal coming down into a building from a remote tower via a “Donor” antenna.

HPA (or PA) – High Power Amplifier

LNA – Low Noise Amplifier

MCU – Master Control Unit

MGC – Manual Gain Control

OSC – Oscillate – When the donor antenna signal gets back into the DAS, oscillation will occur. Hence there must be isolation between the donor antenna and the DAS system. A directional donor antenna is important in preventing oscillation.

Over temp – When the internal temperature reaches a pre-set limit.

RFM – Radio Frequency Module

S/D – Shut down

SMA – Sub Miniature [Coaxial Connector] version A

PSU – Power Supply Unit

UL – Uplink – The signal being sent up to a remote tower from a DAS

V.S.W.R. - Voltage Standing Wave Ratio – Measurement of the efficiency of an RF system.

End of Document